



BY HIDROMAS

TELESCOPIC CYLINDER TECHNICAL INFORMATION

GHS 155 x 4 x 5180 H

PRODUCT CODE: 4315545180625

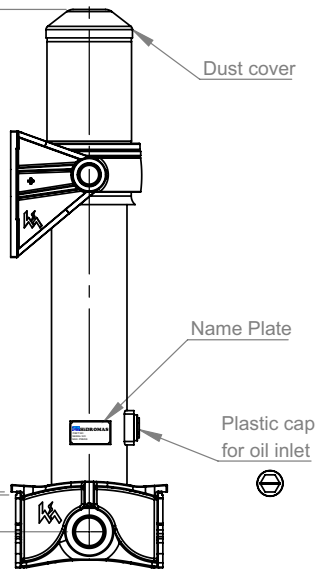
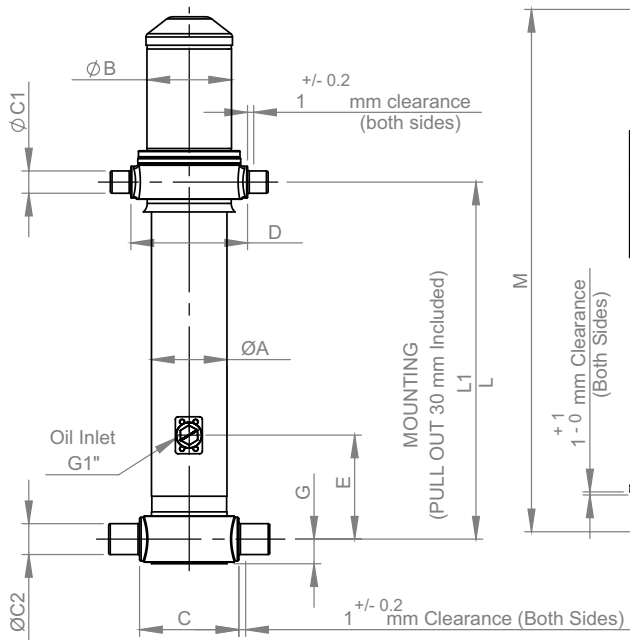

- A : 174 mm
- B : 273 mm
- C : 215 mm
- C1 : 65 mm
- C2 : 60 mm
- D : 340 mm
- E : 190 mm
- G : 60 mm
- L : 1020 mm
- *L1 : 1050 mm
- M : 1634 mm

155 x 4 x 5180 H
 No of Stage: 4
 First Stage Tube Diameter: 155 mm
 Stroke Length: 5180 mm
 Cylinder Type: H

EFFECTIVE DIAMETER (mm)	245	220	197	175	155	135	116	98	80	63	47
THRUST AT 250 bar (tons)	117.8	95	76.2	60.1	47.1	35.8	26.4	18.8	12.6	7.8	4.3

BRACKET KIT: 47000126

- P : 42.5 mm
- R : 60.8 mm
- S : 70 mm
- T : 157 mm
- U : 277 mm
- V : 70 mm
- Y : 148 mm
- Z : 286 mm

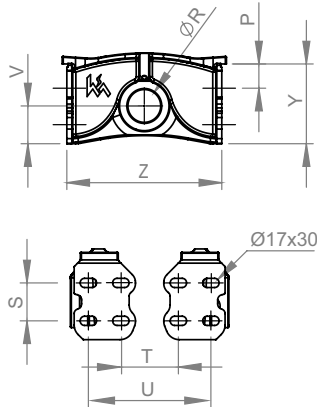

* Brackets are optional
 Weight: 19.6 Kg

LIFTING BRACKET KIT: 47000121

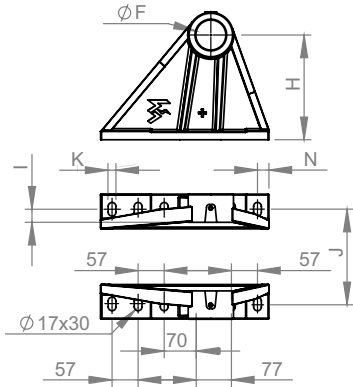

- F : 65.5 mm
- H : 229 mm
- I : 28.5 mm
- J : 399 mm
- K : 17 mm
- N : 25 mm

* Lifting Bracket kit are optional
 Weight: 25 Kg

FORMULATION

- St : Stroke mm
- BL : Body Length mm
- Ro : Rear Overhang mm
- PI : Pivot Length mm
- α° : Tipping Angle

$$\alpha^\circ = \frac{St \times 60}{PI}$$

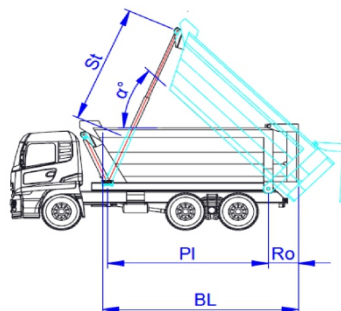

SPECIFICATIONS

- *Inc 30 mm Pull Out : Tolerance +20 ; 0
- # Max. Working Pressure : 250 Bar
- Working Volume : 66.3 L
- Cylinder Weight : 261 Kg
- Hard Chromed All Stages 25 micron (±5)
- All Cylinder Materials are st 52 Cold Drawn Tubes
- Standard Cylinder is Painted RAL 9005 (Jet Black)
- With Thickness of 40 to 50 micron
- # Max. working pressure is not related to max. Cylinder load (end of stroke) ;
- Significant unloading required before tipping end of stroke.
- In addition to this, the the truck rpm must be idle level at the end of stroke.