



BY HIDROMAS

# TELESCOPIC CYLINDER TECHNICAL INFORMATION

GHS 175 x 5 x 8130 H

PRODUCT CODE: 4317558130649

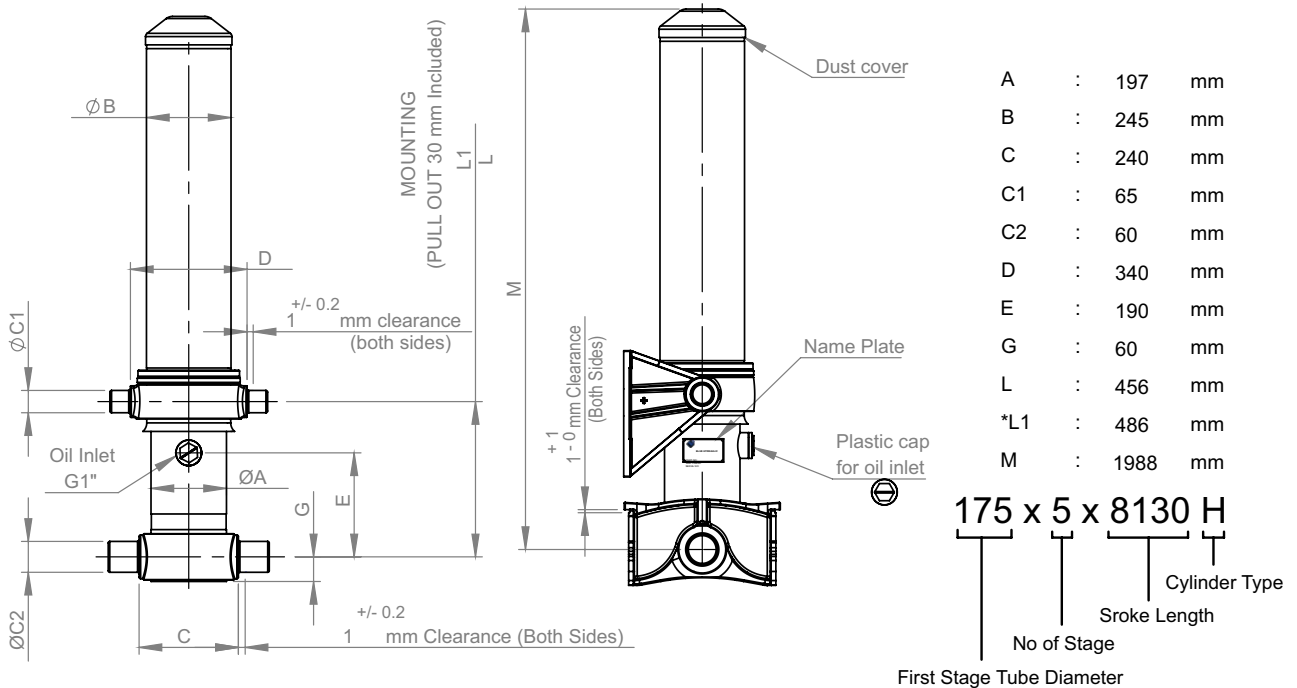

EFFECTIVE DIAMETER (mm)	245	220	197	175	155	135	116	98	80	63	47
THRUST AT 250 bar (tons)	117.8	95	76.2	60.1	47.1	35.8	26.4	18.8	12.6	7.8	4.3

**BRACKET KIT: 47000125**

- P : 42.5 mm
- R : 60.8 mm
- S : 70 mm
- T : 198 mm
- U : 318 mm
- V : 73.5 mm
- Y : 151 mm
- Z : 368 mm

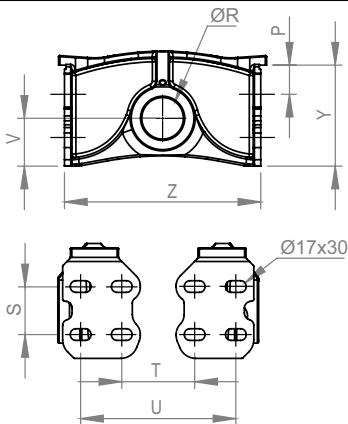

\* Brackets are optional  
Weight: 29.6 Kg

**LIFTING BRACKET KIT: 47000121**

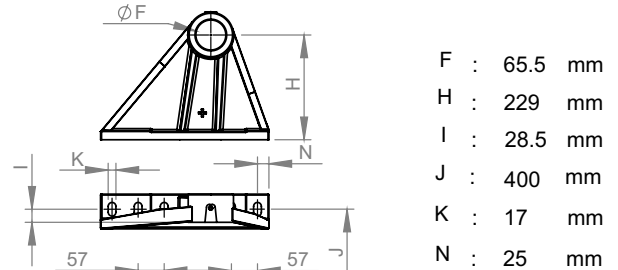

\* Lifting Bracket kit are optional  
Weight: 9.5 Kg

**FORMULATION**

- St : Stroke mm
- BL : Body Length mm
- Ro : Rear Overhang mm
- PI : Pivot Length mm
- $\alpha^\circ$  : Tipping Angle

$$\alpha^\circ = \frac{St \times 60}{PI}$$

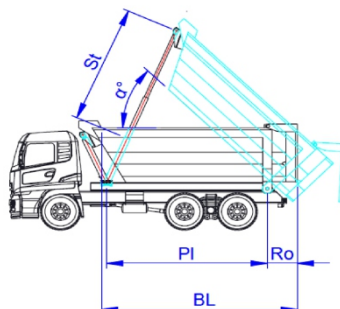

**SPECIFICATIONS**

- \*Inc 30 mm Pull Out : Tolerance +20 ; 0
- # Max. Working Pressure : 250 Bar
- Working Volume : 160 L
- Cylinder Weight : 422 Kg
- Hard Chromed All Stages 25 micron ( $\pm 5$ )
- All Cylinder Materials are st 52 Cold Drawn Tubes
- Standard Cylinder is Painted RAL 9005 (Jet Black)
- With Thickness of 40 to 50 micron
- # Max. working pressure is not related to max. Cylinder load (end of stroke) ;
- Significant unloading required before tipping end of stroke.
- In addition to this, the truck rpm must be idle level at the end of stroke.