

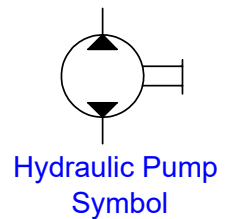

TELESCOPIC CYLINDER TECHNICAL INFORMATION

GEAR PUMP 105 CC ECO
BI-REAR PORT-4H ISO (DM)

PRODUCT CODE: GPBI3510541133

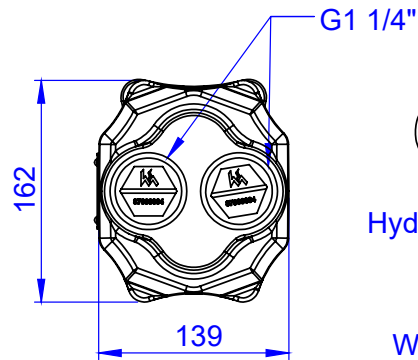
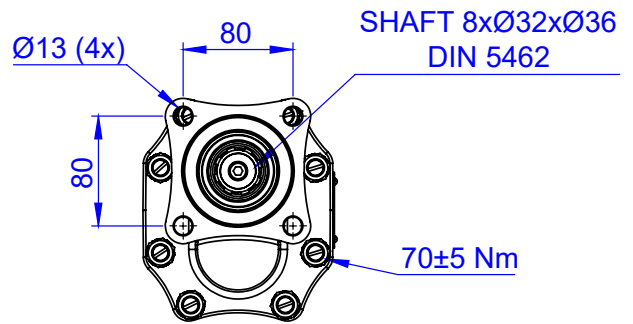
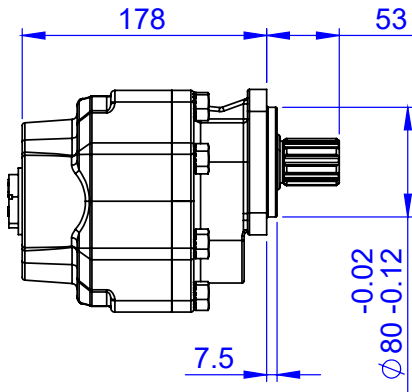

Weight: 16 Kg

Specifications

Displacement	Q	l.p.m	105
Max. Continuous Pressure	P1	bar	225
Max. Intermittent Pressure	P2	bar	240
Max. Peak Pressure	P3	bar	265
Max. Intermittent Speed	n1	r.p.m	3500
Max. Continuous Speed	n2	r.p.m	1500
Min. Intermittent Speed	n3	r.p.m	350
Oil Temperature	T	°C	-25~80
Recommended Oil Viscosity	V	cSt	12~100
Seal type	-	-	VITON/NBR
Paint	-	RAL	7024

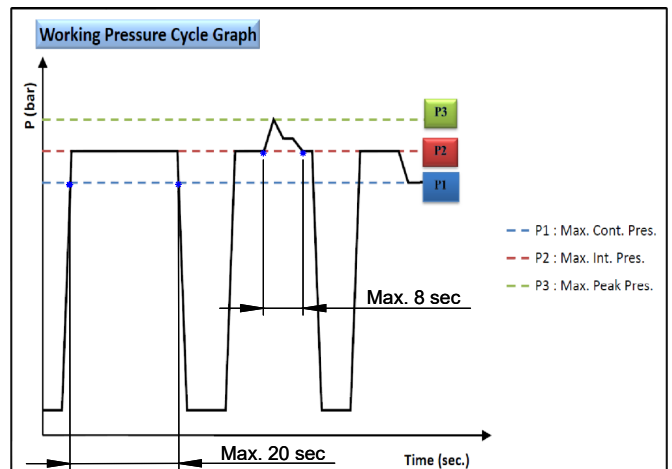

GENERAL NOTES:

This Pump is recommended with bearing Co-Axial PTO..

Standard Hidromas Pumps are used with two seals. One of them is NBR seal that can be reached 80°C and the second one is VITON seal that can be reached 220°C.

For different working conditions please contact our technical sales department.

For extended life or for higher duty applications, 25µm absolute return line filtration is recommended. Oil cleanliness to be maintained to ISO 4406 class 19/16.

Salt spray test conducted as per std ASTM B117 for min 300 hrs.